

KOMATSU

PC2000-11



Photos may show equipments not available in your area

Hydraulic excavator

Engine power
794 kW / 1065 HP @ 1800 rpm

Operating weight
201500 kg

Bucket capacity
12.0 m³

Walk-around



Engine power
794 kW / 1065 HP @ 1800 rpm

Operating weight
201500 kg

Bucket capacity
12.0 m³

Excellent economy and high productivity

Reliability

- Highly durable structure parts and strengthened work equipment
- Long life track parts and extended life of carrier rollers
- Reliable double sealing structure for hydraulic cylinder
- New "Kprime" tooth system with intuitive lock for increased safety, reliability and productivity

Productivity, economy & ecology

- EU Stage V compliant Komatsu engine
- New Power plus mode, productivity increased up to 12%
- Optimized P mode, fuel efficiency increased up to 7% (vs PC2000-8 P mode)
- Enhanced efficiency thanks to powerful and smooth work equipment operation
- Auto deceleration, auto idling system and auto idle stop function
- ECO guidance, ECO gauge, and fuel consumption gauge

Safety features

- New "full 45° access", hydraulically operated stairway and rear access stairs
- Operator's cab OPG level 2 (ISO 10262)
- Lock lever auto lock function
- Emergency engine stop switch and fuel cut-off lever

Comfort features

- Comfortable air-suspension seat with console mounted arm rests
- Low vibration and low noise cab with two large capacity automatic air conditioning units

Maintenance features

- Spacious walkways for safe inspection and easy maintenance of main components
- Maintenance information is displayed on the monitor screen

Information & Communication Technology (ICT)

- High resolution, easy-to-use color monitor provides powerful support for energy saving operation
- Operator identity function for improved machine management and production records
- KomVision surround view system with new large monitor (10 inch)

Komtrax Plus

- Komtrax Plus allows immediate machine diagnostics
- Wireless LAN system



Productivity

Komatsu technology

With the knowledge and field experience from over a century of research, production, and customer feedback, Komatsu can develop high quality engine, hydraulic and electrical components designed to work efficiently with one another in an intelligent total control system. This Komatsu technology brings our new generation excavators to the next stage with improved productivity and savings.

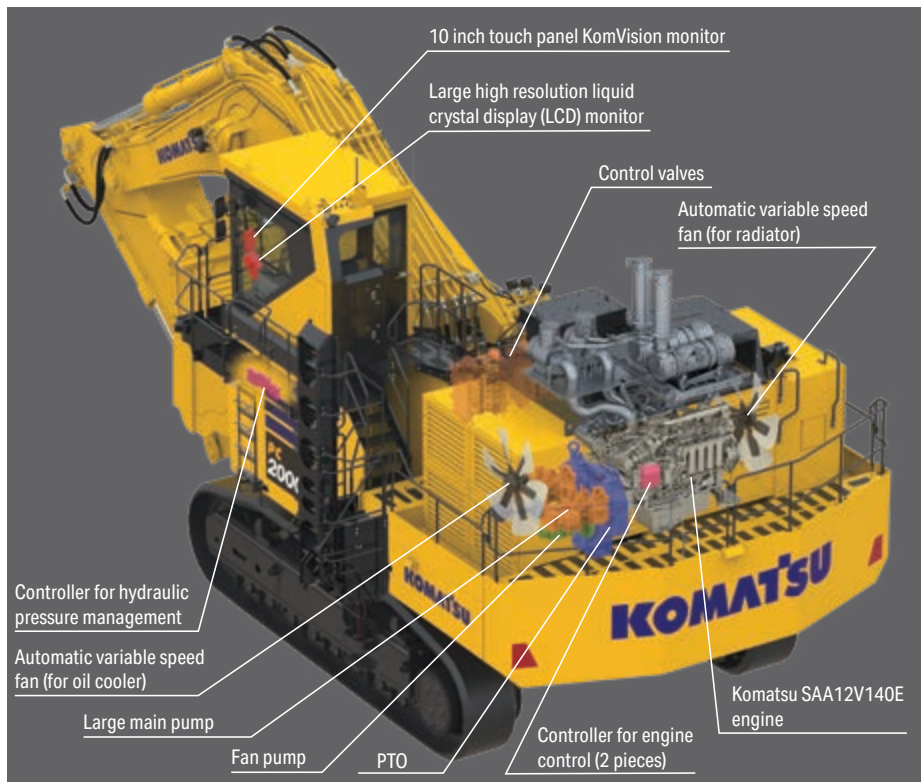

Powerful and fuel efficient: total power management

PC2000-11 is equipped with the new Komatsu SAA12V140E-7 engine that features clean, fuel efficient and powerful performance. The hydraulic system was designed to be more efficient and in combination with an on-demand power control system, fuel efficiency is significantly improved. Production costs are reduced and the PC2000-11 moves more material per unit of fuel. PC2000-11 is a new generation of powerful, clean and economical machines.

Selectable working modes

The PC2000-11 features four different working modes to cater machine performance to application demands and working conditions. Working mode options of Power Plus (P+), Power (P), and two Economy modes (E0 and E1) can be selected using a shortcut button on the machine monitor. With the selectable working modes, operators can ensure that the machine is working to deliver the best combination of productivity and fuel efficiency.



High productivity with Power Plus mode

The introduction of the new Power Plus (P+) mode yields great productivity gains.

P+ mode productivity

increased by **12%**

vs PC2000-8 P mode (90° swing and loading onto truck)

P mode fuel efficiency

increased by **7%**

vs PC2000-8 P mode (90° swing and loading onto truck)

E0 mode fuel consumption

reduced by up to **9%**

vs PC2000-8 P mode (90° swing and loading onto truck)
Fuel consumption data obtained with prototype machine test.

Optimized electrical valve control

Improved work equipment speed

Digging speed is improved by reduction of hydraulic loss when arm digging.



Shockless boom control

The PC2000-11 boom circuit features a double-check slow return valve that provides a boom cylinder cushion to improve operator comfort, reduce shock and reduce material spillage during the loading process.

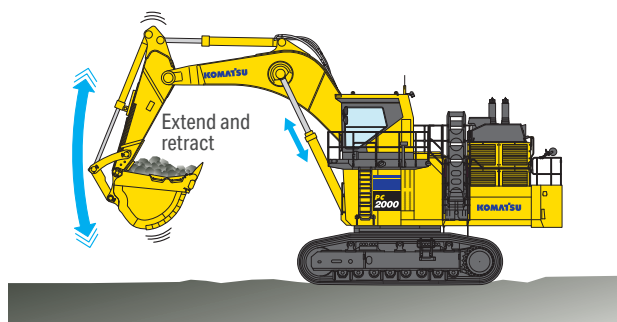

Improved operability

Optimized spool control by electronic pilot control provides smoother compound movement.

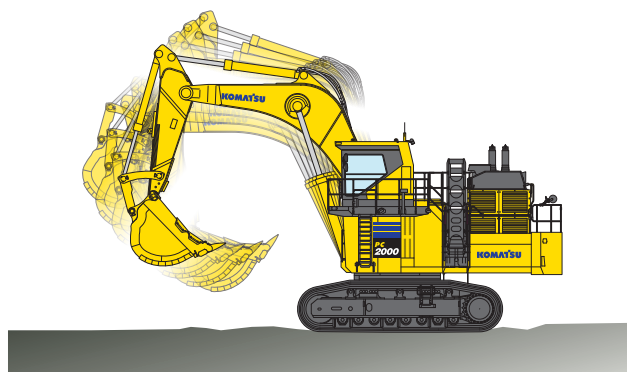

Two-mode setting for boom

Smooth mode provides easy operation for gathering blasted rock and scraping operations. When maximum digging force is needed, switch to Power mode for more effective excavating.

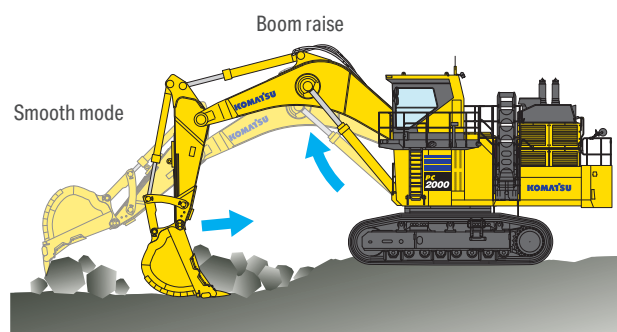

Heavy lift mode

Turning the heavy lift mode switch on activates the all-out power delivery system to increase the lifting force of the boom by about 10%. This is beneficial when handling rock and during heavy lifting applications.

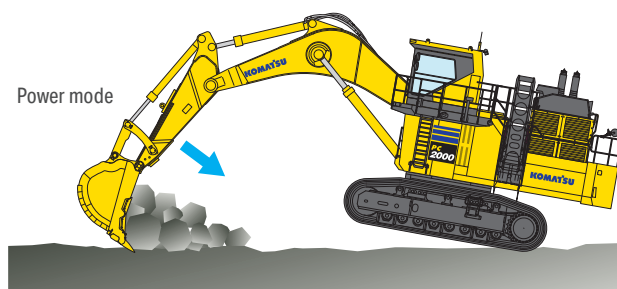
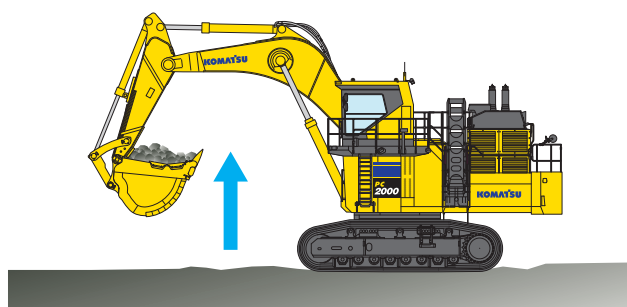

Ecology & economy

Komatsu's new emission regulations-compliant engine

Komatsu provides a powerful and economical EU Stage V compliant engine with latest emission control technologies and fuel saving features.

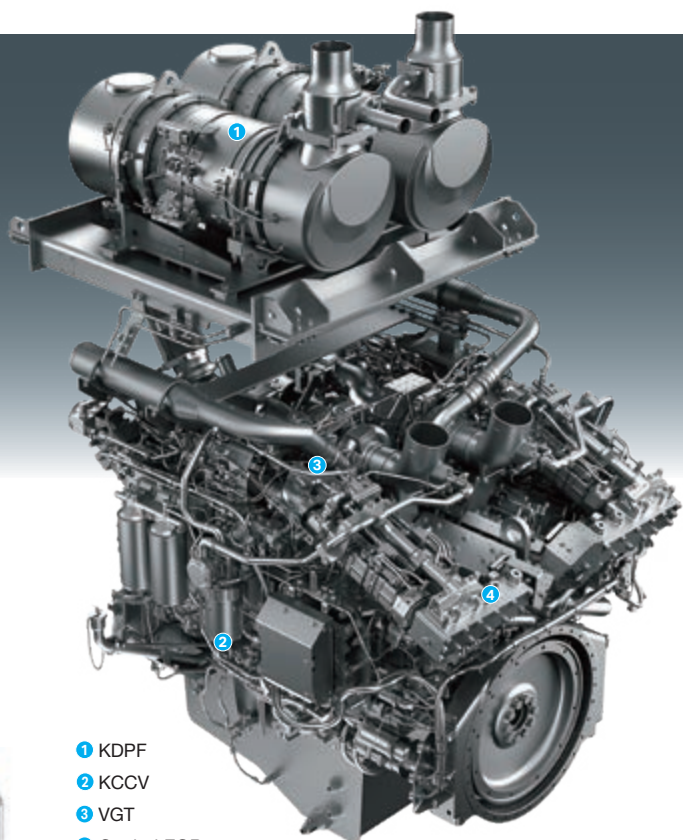

- 1 KDPF
- 2 KCCV
- 3 VGT
- 4 Cooled EGR

Heavy-duty aftertreatment system

Komatsu Diesel Particulate Filter (KDPF) reduces Particulate Matter (PM) by more than 80% when compared to Tier 2 levels. Special oxidation catalyst and extra fuel injection in the exhaust stream can decompose accumulated soot in the KDPF filter by either active or passive regeneration. This system does not require any additional operator's action or interrupt normal operation.

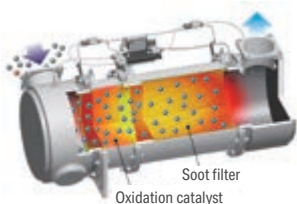

Heavy-duty cooled Exhaust Gas Recirculation (EGR) system

The system recirculates a portion of exhaust gas into air intake and lowers combustion temperatures, thereby reducing NOx emissions. Furthermore, while EGR gas flow is increased, by incorporating a high-efficiency and compactly designed cooling system, the system achieves a dynamic reduction of NOx, while helping reduce fuel consumption.

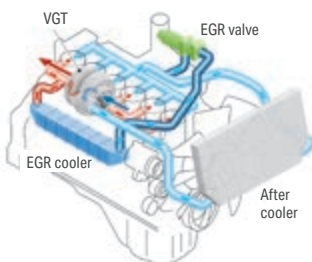

High Pressure Common Rail (HPCR) fuel injection system

The system is designed to achieve an optimal injection of high-pressure fuel by means of computerized control, thereby bringing close to complete combustion to reduce Particulate Matter (PM) emissions.

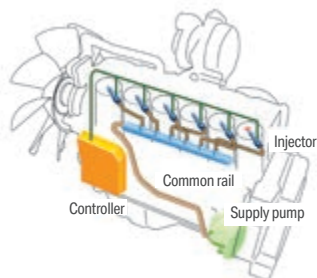

Variable Geometry Turbocharger (VGT) system

The VGT system features Komatsu design hydraulic technology for variable control of air-flow and supplies optimal air according to load conditions. The upgraded version realizes better exhaust temperature management.

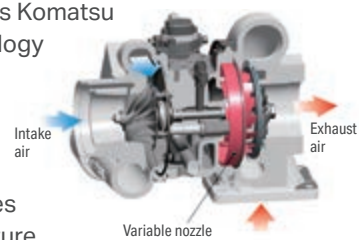

Komatsu Closed Crankcase Ventilation (KCCV)

Crankcase emissions (blow-by gas) are passed through a KCCV filter. The oil mist trapped in the filter is returned back to the crankcase while the filtered gas is returned to the air intake.



Electronic control system

Conditions of the engine are displayed via an on-board network on the monitor inside the cab, providing necessary information to the operator. Furthermore, managing the information via Komtrax Plus helps customers engage in appropriate maintenance.

ECO guidance

While the machine is in operation, the monitor panel provides guidance to the operator to help promote efficient machine operation.

ECO gauge & fuel consumption gauge

The monitor screen is equipped with an ecology gauge and a fuel consumption gauge representative of momentary fuel rate. The operator can set a fuel consumption target (within the range of the green display), enabling the machine to be operated more efficiently.

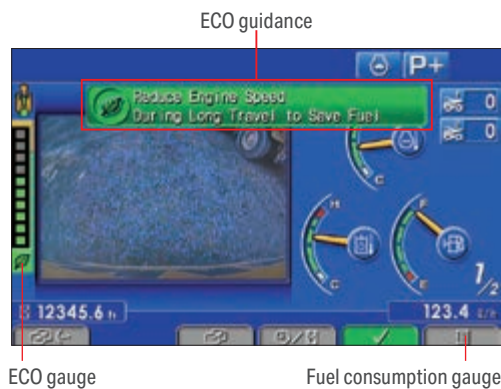

Auto idle shutdown (adjustable)

When the engine has been idling for an operator defined interval, the engine stops automatically to reduce unnecessary fuel consumption and exhaust emissions. The duration before the engine shutdown can be easily programmed.

Auto deceleration and auto idling system

The machine is equipped with the auto deceleration system (1400 rpm), reducing operating noise as well as fuel consumption. The auto idling system enables the engine idling speed to be set at a lower speed.

Power module packaging for ultra low-noise operation

Noise sources such as the engine, cooling fan, and hydraulic pumps are packaged in the power module. Large sound absorbing blades attached on the air intake and exhaust outlet block noise transmission. Combined with the three dimensions hybrid cooling fan, the machine realizes environmentally-friendly operation with amazingly low noise.



Operation record, fuel consumption history, and ECO guidance record

The ECO guidance menu enables the operator to check the operation record, fuel consumption history and ECO guidance record from the ECO guidance menu, with a single touch, thus assisting operators with reducing total fuel consumption.

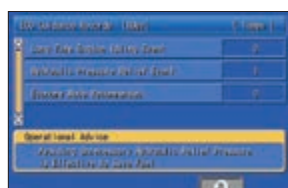

ECO guidance record



Operation record

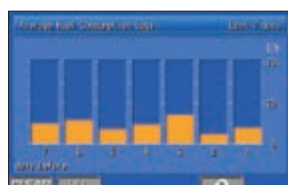

Fuel consumption history



Reliability

Power module

Reduced inspection/ maintenance and overhaul man-hours contribute to lower the Total Cost of Ownership

Power module packaging

Engine, radiator, oil cooler, hydraulic pumps and PTO are packaged within the power module. This design facilitates installation and removal of components, contributing to the reduction of maintenance transportation and overhaul hours.

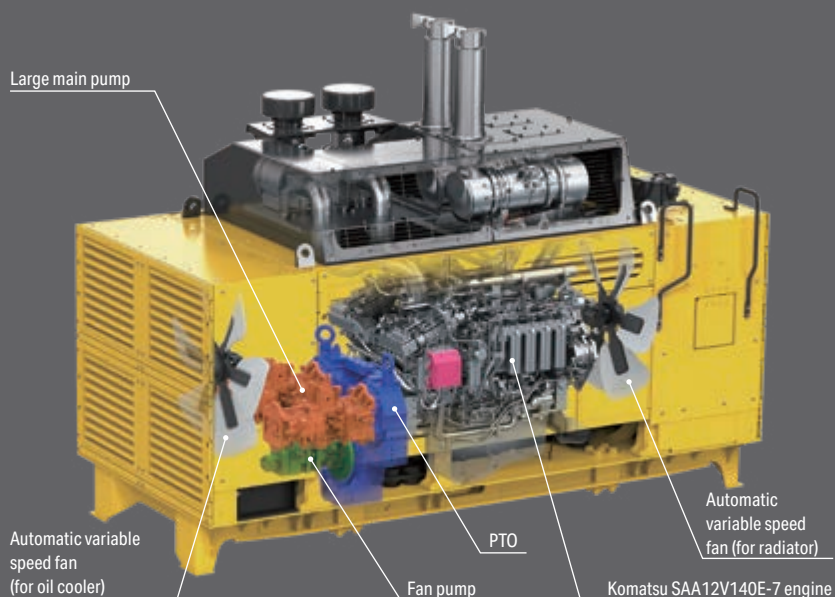

Simple construction and larged components for easy checking and maintenance

The use of a single-engine, the location and orientation of hydraulic pumps and simplified hydraulic circuit enables reduced hours required for inspection and maintenance.

High cooling efficiency machine design

Increased oil cooler capacity lowers the heat balance temperature of hydraulic oil to realize lower operating temperatures. Heat-resistant rubber seals are used in hydraulic pumps and cylinders to achieve high durability of components. These improvements dramatically extend the service life of the hydraulic system.

Durable swing circle with triple-roller bearing

Large capacity triple-roller bearing is used for the swing circle. The swing circle exhibits excellent durability despite the high loads created during heavy excavation.

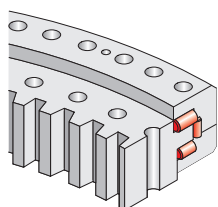

Strengthened frame structure

Revolving frame, center frame and crawler frame have been strengthened to exhibit excellent durability in the most challenging applications.

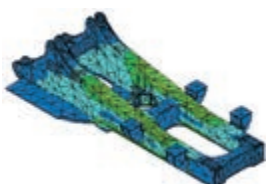

Strengthened boom

Thanks to the integration of newly designed side plates and the shape change of the boom's top casting, the boom exhibits excellent durability and is highly resistant to bending and torsional stress.

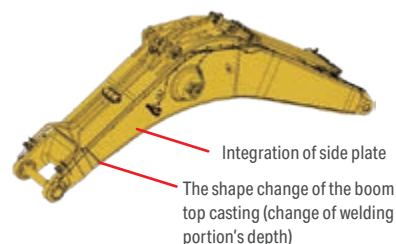

Arm rock protector

Arm rock protector is equipped as standard. The protector guards the arm greasing piping against impact.



Arm rock protector

Wear-resistant float pin

Boom top pin and arm top pin are floating type. Since the pin can freely rotate, it receives less friction load and exhibits excellent reliability and durability. Fixed type pin for arm top is available as option complying with operating conditions of select regions.

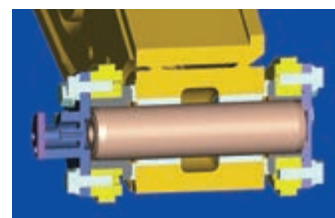

Double sealing structure for hydraulic cylinder

Additional scraper and sub dust seal in all work equipment cylinders improves dust and dirt protection and prolongs cylinder and hydraulic system service life.

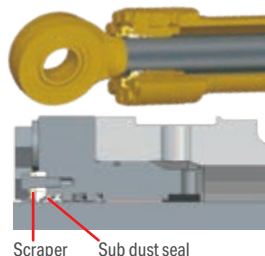

Extended life enlarged carrier rollers size

Durable undercarriage structure with enlarged carrier roller diameter to extend service life and synchronize maintenance with other undercarriage parts.

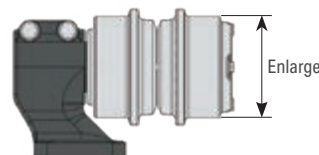

Sturdy guard and large track link

Travel motors are shielded by sturdy guards. They prevent the motors from being damaged by the thrust of rocks.

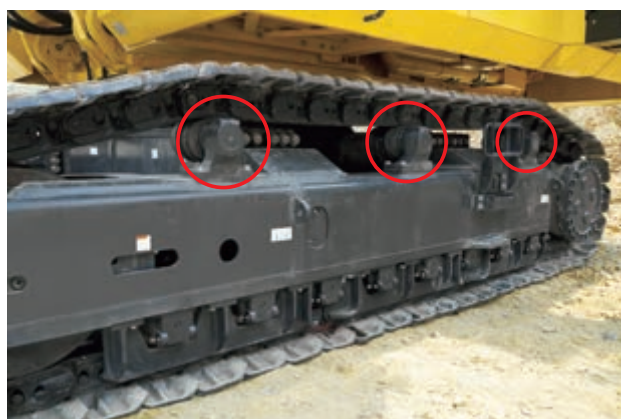

Heavy duty bucket equipped with Kprime tooth system (option)

Reliability with intuitive handling and higher productivity.



Safety

Operator cab specially designed for mining

Operator cab provides a comfortable working environment. Sturdy cab of solid construction, with top guard conforms to OPG level 2 (ISO 10262).



45° access stairway

The machine is equipped with a hydraulically operated stairway. All stairways on this machine are at 45° so that operators can access the cab easily.



Seat belt caution indicator

Lights up when seat belt is not applied.



Lock lever auto lock function

If the work equipment lever is not in the neutral position when the hydraulic lock lever is released, the equipment is automatically stopped. The auto stop state is shown on the monitor screen.

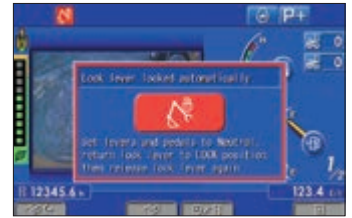

Engine shutdown secondary switch

Installed on the console and used to turn off the engine.



Emergency engine stop switch & fuel cut-off lever

To ensure the safety of operators and maintenance crews at all times, the machine is outfitted with five emergency stop devices. They are located in the cabin (1), on the power module (2), on the access stairway (1) and beneath the revolving frame (1). The fuel cut-off lever on the revolving frame stops the engine from the ground.

Emergency engine stop switch



Fuel cut-off lever



Emergency engine stop switch

Safety equipment

Slip-resistant plates



LED working light

LED maintenance light

- Inside of cab base
- Inside of power module (3 places)

Interconnected horn and flashing light

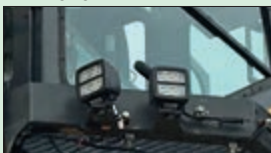

Rope ladder for emergency egress



Lock lever

Dual rearview mirror

Wide catwalk with handrail

Hammer for emergency escape

Fire extinguisher (optional)

Travel alarm

Seat belt retractable

Beacon (optional)

Comfort

Comfortable working space

Excellent operational visibility

Wide front and side windshields coupled with integrated console provides excellent visibility for safe and comfortable operation.



Low noise and low vibration with cab damper mounting

Integrated structure of cab and damper mounts, in combination with power module packaging, contribute to low vibration and noise levels

Spacious and comfortable cab design pressurized cab

The large cab, exclusively designed for mining applications, offers maximum comfort even in extreme climate and after long operation hours. With improved air tightness it is pressurized to prevent dust from entering. A redesigned twin air conditioning system efficiently cools and heats the cab to keep operators comfortable in the most challenging environments.

Comfortable air suspension seat with heater

The seat with air suspension reduces the vibration transmitted to the operator. Depending on the operator's weight and physique, the cushion can be adjusted and the seat can slide fore/aft and vertically. The work equipment control consoles are integrated into the seat suspension for additional operator comfort and to reduce fatigue.

Standard equipment

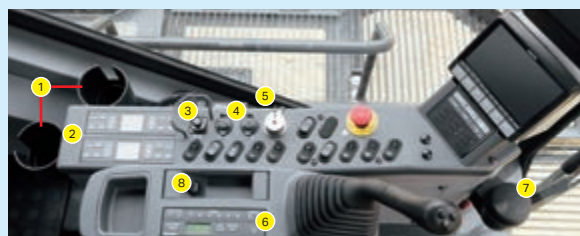

- 1 Cup holder
- 2 Air conditioner control panel
- 3 Cigarette lighter (24 V)
- 4 2 × 12 V socket
- 5 Magazine box
- 6 Handling radio
- 7 Ashtray
- 8 Auxiliary input jack

Trainer's seat diagonally behind the operator

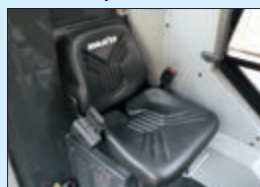

Floor mat

Dual rear view heated mirror as standard



High back air suspension seat with heater

Sun shield

Defroster (Conform to the ISO 10263-5)

LED room light

Sliding window glass (left side)

Utility box

Large twin wiper

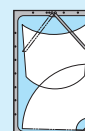

Maintenance

Advanced layout for easy checking and maintenance

Catwalk surrounding the power module and center walkway provides easy access to the inspection and maintenance points.

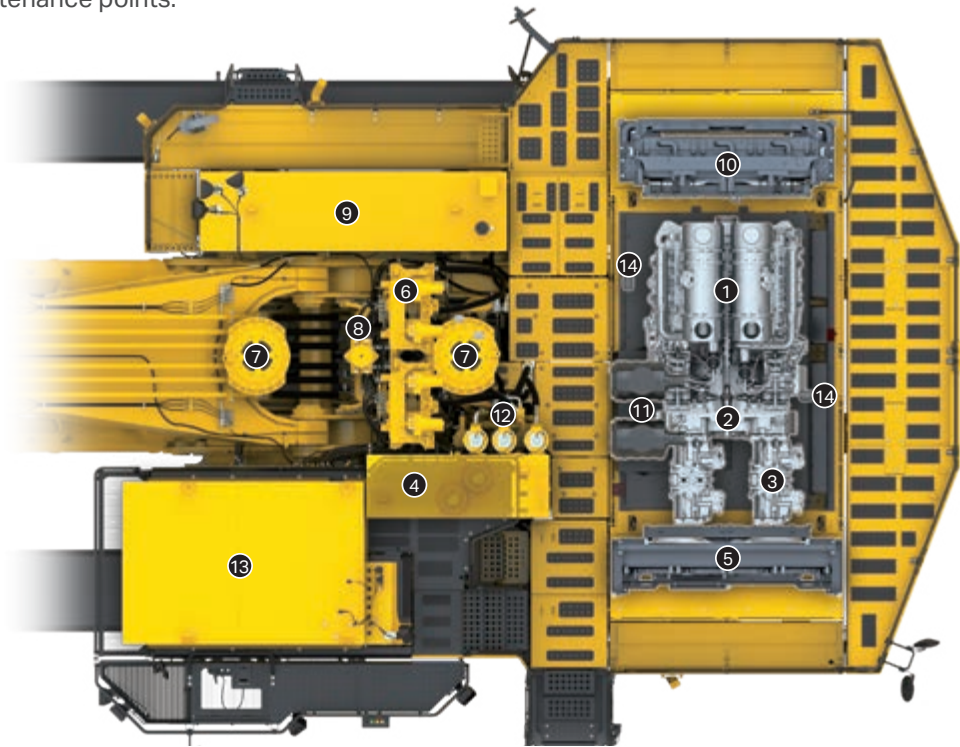

- ① Engine
- ② PTO
- ③ Hydraulic pump
- ④ Hydraulic tank
- ⑤ Oil cooler
- ⑥ Control valve
- ⑦ Swivel motor
- ⑧ Swivel joint
- ⑨ Fuel tank
- ⑩ Radiator
- ⑪ Air cleaner
- ⑫ Hydraulic oil filter
- ⑬ Cab
- ⑭ Maintenance light

Centralized filters

Centralized filters contribute to easy maintenance.

Remote drain piping enables drainage from the ground

Remote drain piping provided to drain hydraulic oil, PTO oil, engine oil and coolant enable performing drainage work from the ground.

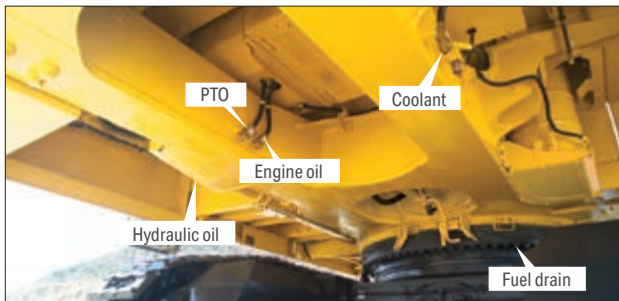

Service center standard

Collective arrangement of drain and filler ports for fuel, oil, grease and coolant on the service center, which is hydraulically moved up and down, makes quick servicing from the ground possible.



Automatic greasing system

Greasing work equipment and bucket is fully automated. Since the system carries out automatic greasing at regular time intervals, greasing is hassle-free.

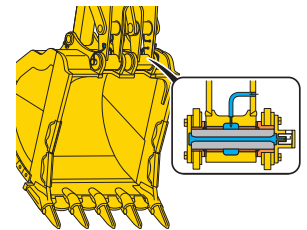

Large fuel tank

3400 l large fuel tank enables continuous operation for 24 hours.

Large capacity grease tank easy-to-supply refill piping

The 200 l grease tank is large enough to perform 24 hours operations. The standard remote refill port with in line filter enables the grease tank to be serviced from ground-level.



Access light with timer and maintenance light

An access light with timer provides light for 90 seconds to allow the operator to get off the machine. This light can be used as a continuous maintenance light.



Battery isolator and starting motor isolator

During inspection and maintenance or long-term storage, the isolators serve to isolate both positive and negative terminals of the battery and starting motor.



Jump start receptacle

Jump start receptacle allows starting engine from external power source.



Easy cleaning of radiator and oil cooler

The hydraulically driven fan can be reversed to facilitate cleaning of the cooling unit. In addition, this feature contributes to reducing warm-up time in low temperatures.

Easy maintenance of air conditioner units

Enlarged unit space, easy to check and exchange air conditioner units.



Long-life oil, filter

Uses high-performance filtering materials and long-life oil. Extends the oil and filter replacement interval.

Engine oil & engine oil filter	every	500 hours
Fuel main filter	every	1000 hours
Hydraulic oil filter	every	1000 hours
Hydraulic oil	every	5000 hours

Coolant filter

Filters out contaminants to maintain high cooling efficiency and prevents water pump and core clogging related failures.



Large capacity fuel prefilter (with water separator)

Removes water and contaminants from fuel to enhance the fuel system reliability. The filtering capacity of water and dust has been increased compared to the conventional filter.



Hydraulic return filter clog detection function

Recommends filter exchange and prevents catastrophic damage of hydraulic system by informing operator of the clogging of hydraulic return filter. The signal can be monitored via Komtrax Plus.



Monitor function

Controller monitors engine oil level, coolant temperature, battery charge and air clogging, etc. If an abnormality is detected, informative details are displayed on the cab monitor to guide the operator on the best course of action.

Abnormality memory function

Monitor stores abnormalities for effective troubleshooting.



Maintenance information

"Maintenance time caution lamp" display

When the remaining time to maintenance is under 30 hours*, the maintenance time monitor appears. Pressing the F6 key switches the monitor to the maintenance screen.

* The setting can be changed within the range between 10 and 200 hours.



Maintenance screen

ICT & KOMTRAX

Large high resolution Liquid Crystal Display (LCD) monitor



Machine monitor with evolutionary interface

The interface has been redesigned to enable the necessary information to be read and understood more easily, while retaining the maneuverability of previous model. A rear view camera image has been added to the default main screen. The

interface has a function that enables the main screen to be switched, thus enabling the optimum screen for the particular work situation to be displayed.

Indicators

- | | | |
|----------------------------|------------------------------------|------------------------------|
| 1 Auto-decelerator | 7 Engine coolant temperature gauge | 12 Engine oil pressure gauge |
| 2 Working mode | 8 Hydraulic oil temperature gauge | 13 Service meter / Clock |
| 3 Camera direction display | 9 Fuel gauge | 14 Fuel consumption gauge |
| 4 Camera display | 10 PTO oil temperature gauge | 15 Guidance icon |
| 5 Truck counter | 11 Engine oil temperature gauge | 16 Function switches |
| 6 ECO gauge | | |

Basic operation switches

- | | | |
|-------------------------|-----------------|-----------------|
| 1 Auto-decelerator | 3 Heavy lift | 5 Wiper |
| 2 Working mode selector | 4 Buzzer cancel | 6 Window washer |

Visual user menu

Pressing the F6 key on the main screen displays the user menu screen. The menus are grouped for each function, and use easy-to-understand icons which enable the machine to be operated intuitively.



- 1 Energy saving
- 2 Machine settings
- 3 Maintenance
- 4 Monitor setting
- 5 Mail check

Switchable main screen

The main display can be cycled by pressing the F3 key.

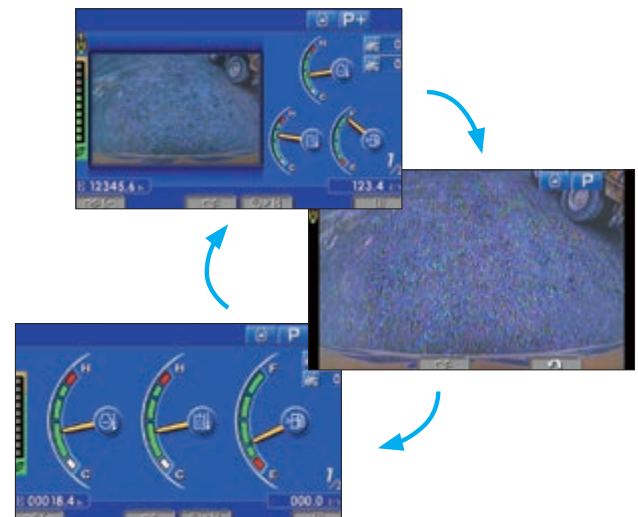

10 Inch touch panel KomVision monitor



KomVision, all around monitoring system

The 7-camera system installed on the PC2000-11 allows quick confirmation of safety on work area. The birds eye view is displayed on the 10 inch KomVision monitor, and a dedicated rear view is displayed on the machine monitor.

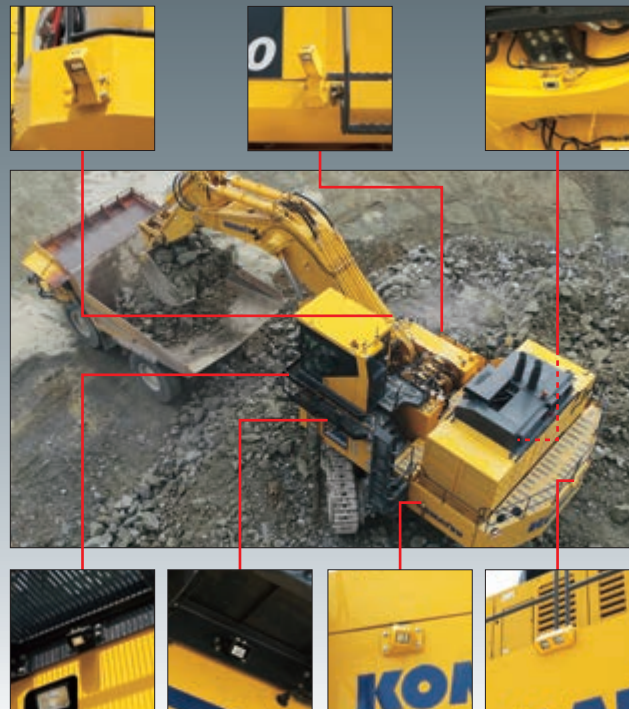

Equipment management support

Komtrax Plus enables expanded monitoring of the fleet via satellite and wireless LAN. Users can analyze "machine health" and performance from a remote location, on a near-real time basis. This includes component condition and trend data. By making this critical information readily accessible, Komtrax Plus is an effective tool in maximizing productivity and lowering operating costs.



KOMTRAX Plus

Monitors large machines' health and supports customers' machine management.

Support for machine management

Komtrax Plus is a management system for large machines. With this system, you can grasp "health condition" and "operating condition" of the machines from distant places via satellite communication, and accordingly you can prevent machine troubles and streamline the machine management.

Machine management with Komtrax Plus

- **Maintenance management:** Manage maintenance schedule and failure prevention maintenance
- **Machine management:** Check lists of jobsites, service meter readings, etc.
- **Operation management:** Check operating condition of each machine
- **Check machine locations:** Check detailed machine sites on map
- **Support in energy saving operation:** Check fuel consumption and CO₂ emissions, and make energy saving operation support report
- **Make forms:** Download displayed data and use them as forms

Energy saving operation support report

It is possible to provide energy saving operation support report and other information useful to customers on the basis of work information such as fuel consumption, idling time, etc.

Specifications

Engine

Model	Komatsu SAA12V140E-7
Type	4-cycle, water-cooled, direct injection
Aspiration	Turbocharged, aftercooled
Engine power	
at rated engine speed	1800 rpm
SAE J1995	794 kW/1065 HP
ISO 9249 / SAE J1349	780 kW/1050 HP
No. of cylinders	12
Bore × stroke	140 × 165 mm
Displacement	30.48 l
Fan drive type	Hydraulic
Governor	All-speed, electronic
Fuel	Diesel fuel, conforming to EN590 Class 2/Grade D. Paraffinic fuel capability (HVO, GTL, BTL), conforming to EN 15940:2016

Hydraulic system

Type	Open-center load-sensing system
Selectable working modes	3
Main pump	
Type	Variable displacement piston pumps
Pumps for	Boom, arm, bucket, swing, and travel circuits
Maximum pump flow	
Attachment, swing and travel	2317 l/min
Fan drive	324 l/min
Hydraulic motors	
Travel	2 × axial piston motors with parking brake
Swing	2 × axial piston motors with swing holding brake
Relief valve setting	
Implement	300 kgf/cm ²
Travel circuit	335 kgf/cm ²
Swing circuit	300 kgf/cm ²
Pilot circuit	33 kgf/cm ²
Hydraulic cylinders	(Number of cylinders-bore × stroke)
Boom	2 – 300 mm × 2647 mm
Arm	2 – 250 mm × 2134 mm
Bucket	2 – 200 mm × 2170 mm

Drives and brakes

Travel gear	Planetary gear
Gradeability	66%
Maximum travel speed	2.7 km/h
Parking brake	Oil disk brake

Swing system

Swing gear	2 × Planetary gears
Swing circle lubrication	Grease-bathed
Swing holding brakes	Oil disc brakes
Swing speed	4.8 rpm

Undercarriage

Track adjuster	Grease
No. of shoes (each side)	49
No. of carrier rollers (each side)	3
No. of track rollers (each side)	8

Service refill capacities

Fuel tank	3400 l
Radiator	190 l
Engine	128 l
Travel gear (each side)	85 l
Swing drive	30 × 2 l
Hydraulic tank	1300 l
Power Take Off (PTO)	40 l

Operating weight (appr.)

Shoes	Operating weight	Ground pressure
Double grouser 810 mm	201500 kg	1.95 kgf/cm ²

Operating weight, including 8700 mm boom, 3900 mm arm, ISO 7451 heaped 12.0 m³ general purpose backhoe bucket, lubricant, coolant, full fuel tank, and the standard equipment.

Environment

Engine emissions	Fully complies with EU Stage V exhaust emission regulations
------------------	--

Dimensions

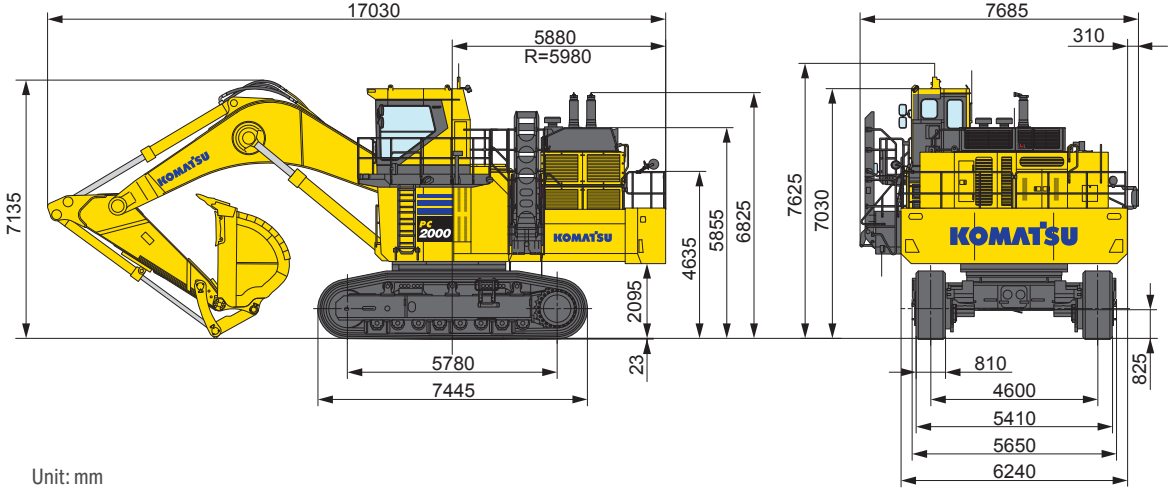

Unit: mm

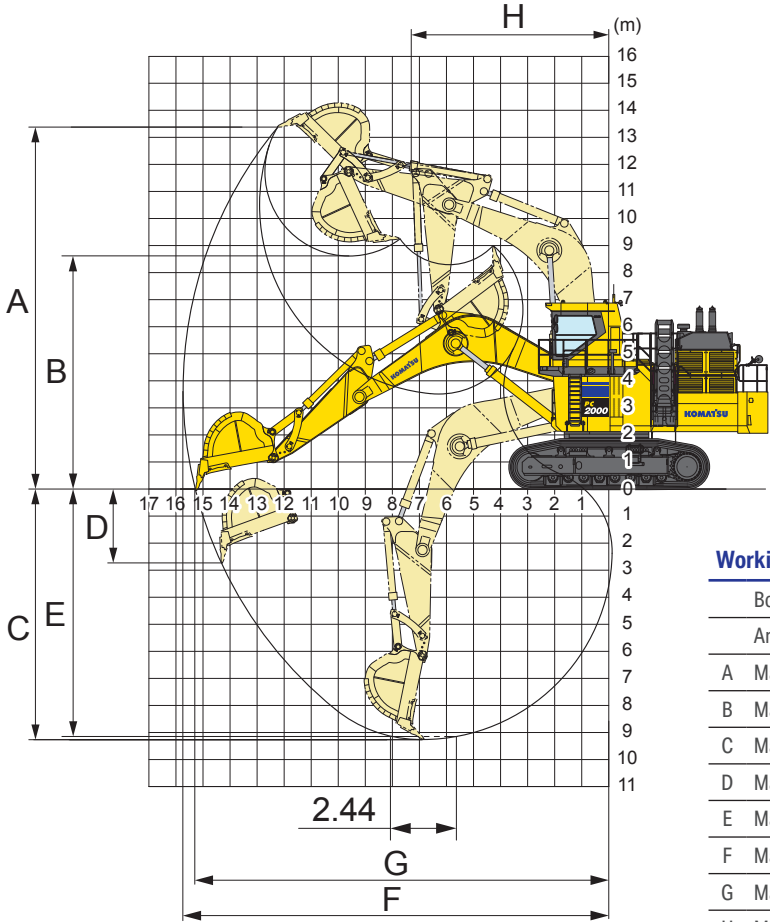

Working range

Boom length	8.7 m
Arm length	3.9 m
A Max. digging height	13390 mm
B Max. dumping height	8640 mm
C Max. digging depth	9245 mm
D Max. vertical wall digging depth	2765 mm
E Max. digging depth of cut for 2,44 m level	9125 mm
F Max. digging reach	15780 mm
G Max. digging reach at ground level	15305 mm
H Min. swing radius	7500 mm
Bucket digging force (SAE J1179)	626 kN/63800 kgf
Arm crowd force (SAE J1179)	586 kN/59700 kgf
Bucket digging force (ISO 6015)	697 kN/71100 kgf
Arm crowd force (ISO 6015)	598 kN/61000 kgf

Transportation guide

Specifications shown include the following equipment:

Backhoe boom **8700 mm** arm **3900 mm** bucket **12.0 m³** shoes **810 mm** double grouser

Work equipment assembly

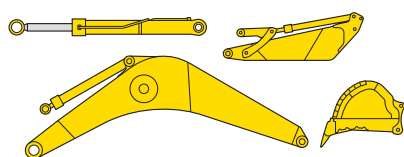

	Length (mm)	Width (mm)	Height (mm)	Weight (t)
Boom	9170	2065	3195	21.5
Arm	5495	1605	2055	13.0
Bucket	3540	2890	2320	10.0

	Length (mm)	Weight (t)	Quantity
Boom cylinder	4270	2.1	2

Cab

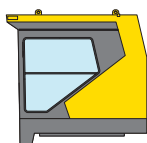

Cab base



Revolving frame

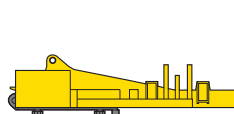

Power module

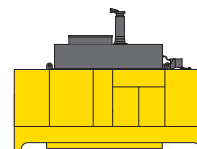

Fuel tank

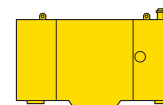

Length (mm)	2885	2100	7575	5215	3100
Width (mm)	1880	2000	3180	2455	875
Height (mm)	2520	2700	2640	3320	2070
Weight (t)	2.0	2.6	26.5	16.4	2.14

Counterweight



Center frame

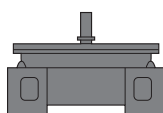

Undercarriage

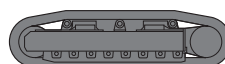

Hydraulic tank



Left floor

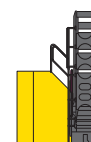

Length (mm)	6240	3815	7435	1860	2510
Width (mm)	1115	3190	1720	1115	3280
Height (mm)	1505	2210	1920	2085	3150
Weight (t)	24.8	18.1	26.0 x 2	1.75	2.3

Others

Catwalk, step, handrail, small removed parts, etc.

Lifting capacity

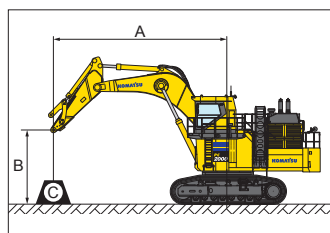

PC2000-11

Equipment:

- Boom: 8.7 m
- Arm: 3.9 m
- Without bucket
- Track shoe width: 810 mm

A: Reach from swing center

B: Arm top pin height

C: Lifting capacity

Cf: Rating over front

Cs: Rating over side

⊗: Rating at maximum reach

Heavy Lift ON

B \ A	⊗ MAX		10.7 m		9.1 m		7.6 m		6.1 m		4.6 m		3.0 m	
	Cf	Cs	Cf	Cs	Cf	Cs	Cf	Cs	Cf	Cs	Cf	Cs	Cf	Cs
7.6 m	*36170 kg	*36170 kg	*45180 kg	45010 kg	*50150 kg	*50150 kg								
6.1 m	*36820 kg	33710 kg	*47020 kg	43680 kg	*53720 kg	*53720 kg	*63730 kg	*63730 kg						
4.6 m	*38160 kg	32100 kg	*49000 kg	42220 kg	*57310 kg	54390 kg	*69770 kg	*69770 kg						
3.0 m	40370 kg	31370 kg	*50720 kg	40760 kg	*60330 kg	52050 kg	*74340 kg	68210 kg						
1.5 m	40740 kg	31550 kg	51370 kg	39660 kg	*61780 kg	50410 kg	*76020 kg	66000 kg						
0.0 m	42300 kg	32690 kg	50620 kg	38950 kg	*61480 kg	49370 kg	*75120 kg	64810 kg	*73340 kg	*73340 kg				
-1.5 m	*42920 kg	35090 kg	*48270 kg	38710 kg	*59060 kg	48950 kg	*71680 kg	64430 kg	*87840 kg	*87840 kg	*57620 kg	*57620 kg		
-3.0 m	*42140 kg	39440 kg			*53750 kg	49160 kg	*65310 kg	64760 kg	*78920 kg	*78920 kg	*86960 kg	*86960 kg		
-4.6 m	*39560 kg	*39560 kg			*42230 kg	*42230 kg	*53820 kg	*53820 kg	*64740 kg	*64740 kg	*75340 kg	*75340 kg		
-6.1 m														

* Load is limited by hydraulic capacity rather than tipping. Ratings are based on ISO standard No. 10567. Rated loads do not exceed 87% of hydraulic lift capacity or 75% of tipping load.

Heavy Lift OFF

B \ A	⊗ MAX		10.7 m		9.1 m		7.6 m		6.1 m		4.6 m		3.0 m	
	Cf	Cs	Cf	Cs	Cf	Cs	Cf	Cs	Cf	Cs	Cf	Cs	Cf	Cs
7.6 m	*32770 kg	*32770 kg	*40210 kg	*40210 kg	*44790 kg	*44790 kg								
6.1 m	*33350 kg	*33350 kg	*41790 kg	*41790 kg	*47880 kg	*47880 kg	*56950 kg	*56950 kg						
4.6 m	*34570 kg	32100 kg	*43500 kg	42220 kg	*51000 kg	*51000 kg	*62210 kg	*62210 kg						
3.0 m	*36700 kg	31370 kg	*44960 kg	40760 kg	*53600 kg	52050 kg	*66140 kg	*66140 kg						
1.5 m	*37840 kg	31550 kg	*45560 kg	39660 kg	*54800 kg	50410 kg	*67530 kg	66000 kg						
0.0 m	*37930 kg	32690 kg	*44970 kg	38950 kg	*54450 kg	49370 kg	*66620 kg	64810 kg	*66940 kg	*66940 kg				
-1.5 m	*37760 kg	35090 kg	*42560 kg	38710 kg	*52200 kg	48950 kg	*63440 kg	*63440 kg	*77770 kg	*77770 kg	*52490 kg	*52490 kg		
-3.0 m	*36960 kg	*36960 kg			*47340 kg	*47340 kg	*57620 kg	*57620 kg	*69640 kg	*69640 kg	*79430 kg	*79430 kg		
-4.6 m	*34470 kg	*34470 kg			*36870 kg	*36870 kg	*47160 kg	*47160 kg	*56740 kg	*56740 kg	*65780 kg	*65780 kg		
-6.1 m														

* Load is limited by hydraulic capacity rather than tipping. Ratings are based on ISO standard No. 10567. Rated loads do not exceed 87% of hydraulic lift capacity or 75% of tipping load.

Standard and optional equipment

Engine

Komatsu SAA12V140E-7 engine	●
EU Stage V compliant	●
Automatic engine warm-up system	●
Dry type air cleaner, double element	●
Large capacity fuel pre-filters with water separator	●
Variable speed cooling fan, hydraulic drive, reversible	●
Coolant filter	●
Auto-decelerator, auto-idling system	●
Auto idle shutdown (programmable)	●
Alternator 24 V/90 A	●
Batteries 2 x 12 V/200 Ah	●
Starter motor 24 V/11 kW	●
Cold area arrangement	○

Hydraulic system

Fully hydraulic, with Open-Center Load-Sensing and engine speed sensing (Pump and engine mutual control system)	●
In-line high pressure filters	●
2 speed travel system with auto shift	●
3 working modes (Power plus, Power, Economy)	●
Pressure Proportional Control (PPC) hydraulic control system	●
Automatic swing holding brake	●
Heavy lift mode	●
Shockless control system for boom	●
Two-mode setting for boom	●

Undercarriage

810 mm double grouser shoes	●
Track frame undercovers (centre)	●
Track guiding guards (each side)	●
Travel motor guards	●
Rock protectors	●
Full length track roller guards	○

Cabin

Top guard, OPG Level 2 (ISO 10262)	●
Heated and ventilated high-back air-suspended seat, console mounted height adjustable arm rests	●
Automatic dual climate control system, with defroster	●
Large high resolution LCD color monitor	●
Bluetooth® radio with USB	●
Auxiliary input (3,5 mm jack)	●
12 V power supply	●
Cigarette lighter and ashtray	●
Beverage holder	●
Sun visor	●
Windshield washer and wipers	●
Mirrors (RH, LH)	●
Washable cab floor mat	●
Trainer seat	●

Service and maintenance

Equipment Management Monitoring System	●
Komtrax Plus	●
Preventive Maintenance (PM) tune-up service connector	●
One-touch engine oil drainage	●
Automatic greasing system	●
Grease gun, electric pump	●
Electric priming pump for fuel	●
Fuel quick charge system	●
Service center with quick drain and fill of all fluids	●
Toolkit	●

LED lighting system

Working lights: 4 boom, 4 cab roof, 3 frame	●
Rear working light (2)	●
Rear deck light (2)	●
Step light with timer (2)	●
Beacon (2)	○

Safety equipment

KomVision surround view system	●
Hydraulically operated stairway	●
Emergency engine stop switches	●
Secondary engine shut down switch	●
Battery disconnect switch	●
Circuit breaker	●
Neutral position detection system	●
Lock lever	●
Audible travel alarm	●
Seat belt indicator	●
Horn, air	●
Wide catwalk	●
Hand rails & guard rails	●
Slip-resistant plates	●
Flashing light connected with horn	○
Full front guard, OPG level 2 (ISO 10262)	○

Work equipment

8700 mm boom	○
3900 mm arm	○
Komatsu buckets	○

Other equipment

Counterweight	●
Strengthened revolving frame underguards	●
Vandalism protection locks	●
Radiator and oil cooler dustproof net	●

Further equipment on request

- standard equipment
- optional equipment

This specification sheet may contain attachments and optional equipment that are not available in your area. Please consult your local Komatsu distributor for those items you may require. Materials and specifications are subject to change without notice.

Your Komatsu partner:

KOMATSU

komatsu.eu

